

The Armor Pendant features a carefully crafted hand-blown glass pendant draped with finished stainless steel chainmail. Pulling from the intricate use of chainmail in Medieval armor, we reinterpret its materiality by creating a balance between the strength that the metal mesh evokes and the delicate and elegant nature of hand-blown glass. Available in two sizes as a single pendant, a cluster of three or five pendants, or a custom cluster.

Armor Pendant Double - Large

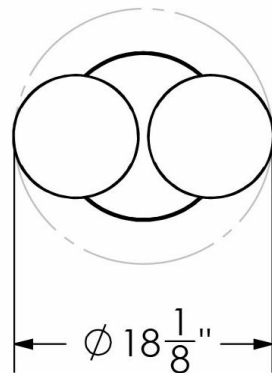
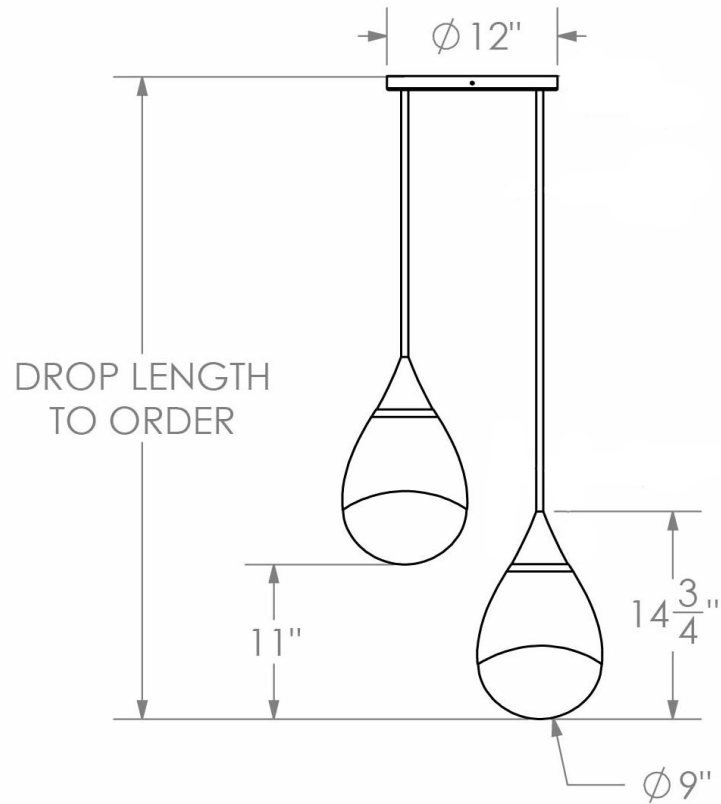

Dimensions

18 1/8"D

Drop length cut to order. Pricing includes up to 78"H. For longer drop lengths please inquire for custom quote.

Materials

hand-blown glass, brass and finished stainless steel chainmail

Finish

satin brass, antique brass, oil-rubbed bronze, satin black, satin nickel or antique nickel

Lead time

8-12 weeks

Lamping

E26 | 120V | 60W

3W dimmable LED bulbs included

120V; 210 lumens; 2200k color temperature

UL listed

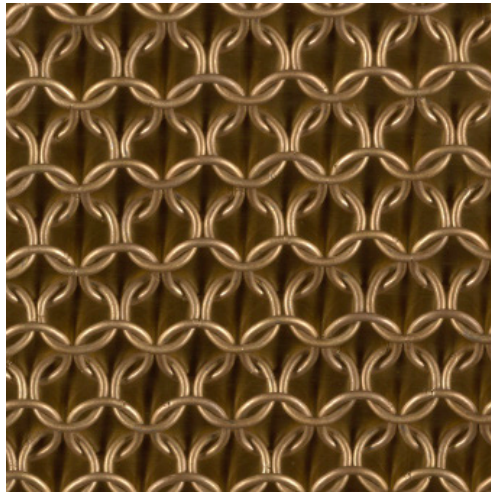

Satin Brass

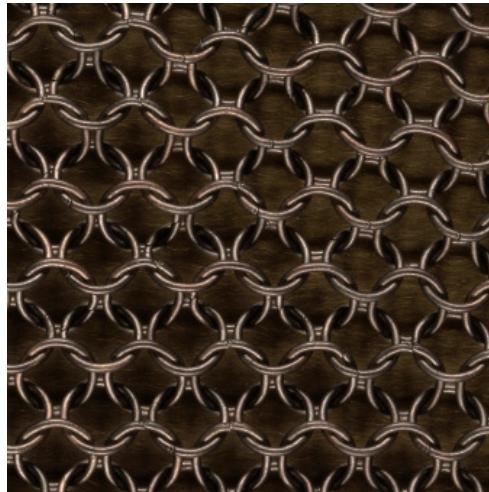

Antique Brass

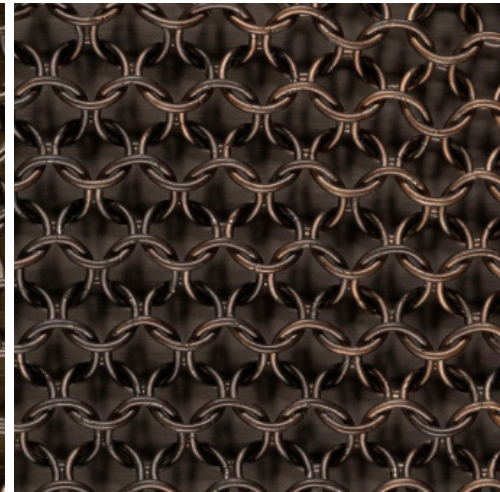

Oil-Rubbed Bronze

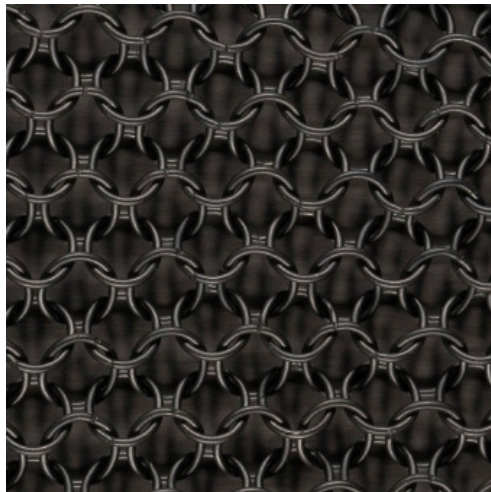

Satin Black

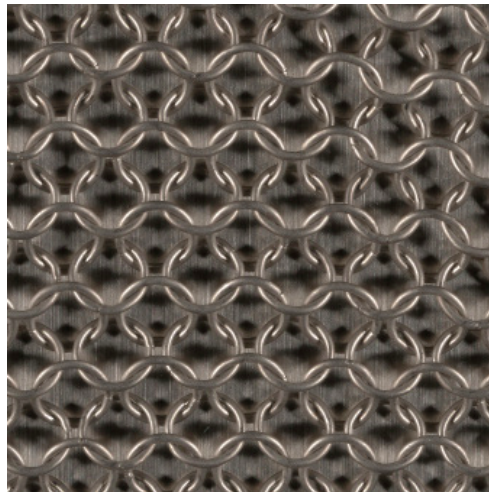

Satin Nickel

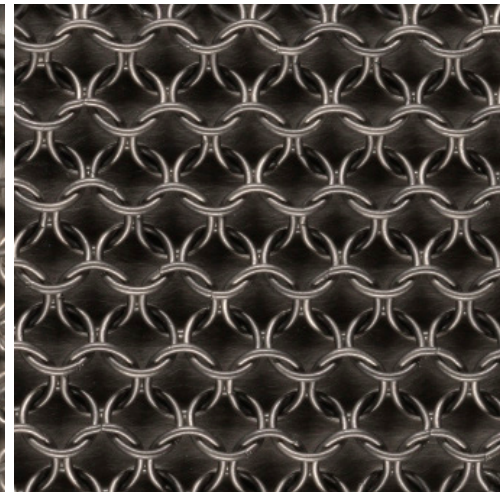

Antique Nickel